



Technical characteristics

- Connections: 3"
- Max Flow-rates: 1000 lt/min
- Max delivery head: 70mt
- Max air pressure: 7 Bar
- Air connections: 3/4"
- Max suction head: 6mt
- Max d. passing solids: 10mm
- Pump casing materials:
 - PP
 - ALUMINIUM
 - SS

DUOTEK diaphragm pumps are characterized by exceptional performance, power and strength, making them ideal for pumping liquids with very high apparent viscosity up to 50000 cps (at 20°C), even if containing suspended solids.

The stall-prevention pneumatic system assures a safe pump running and it does not need lubricated air.

Self-priming dry capacity even with considerable suction head, fine tuning of speed without pressure loss and the possibility of dry operation without suffering damage mean that these pumps offer unrivalled versatility. In addition, the huge choice of construction materials allows selection of optimum chemical compatibility with the fluid and/or environment without neglecting the temperature range.

They are specifically designed for demanding applications with high humidity or in potentially explosive atmospheres (ATEX Certification).

MAIN FEATURES

- . construction's materials: PP, AISI 316, ALUMINIUM
- . Self-priming up to 6m
- . Unlimited dry running
- . Anti-stall pneumatic circuit , easy to maintain
- . possibility to adjust: flow-rate, head and speed
- . ATEX certifications for Zone 1 and 2 in all versions

PUMP KEY CODE

Field 1	Field 2	Field 3	Field 4	Field 5	Field 6	Field 7	Field 8	Field 9	Field 10
AF	00	1000	P	N	T	T	P	N	1

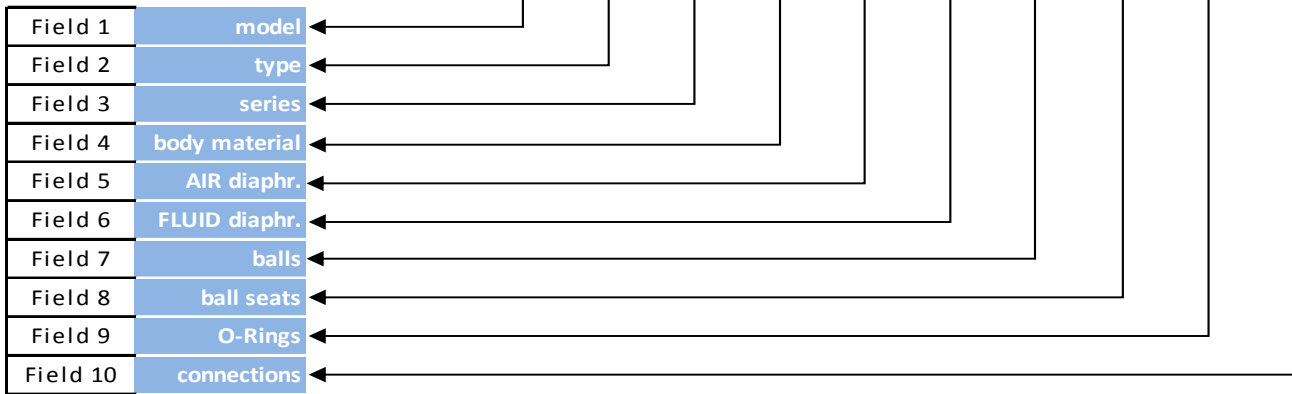

Field 1 **model**
AF Pneumatic Diaphragm Pumps

Field 2 **type**
00 Zone 2 ATEX
X0 Zone 1 ATEX

Field 3	series [l/m]	connection [BSP]	max head [m]	max pressure [bar]	air connection [BSP]	self priming [m]	passing solid [Ø mm]
	0700	DN50 ***	70	7	3/4"	6	8,5

Field 4 **body material**
P Polypropylene
A Aluminium
S SS 316

Field 5 **AIR diaphr.**
H Hytel
M Santoprene

Field 6 **FLUID diaphr.**
T PTFE

Field 7 **balls**
T PTFE
S SS 316
D EPDM
N NBR

PUMP KEY CODE

Field 1	Field 2	Field 3	Field 4	Field 5	Field 6	Field 7	Field 8	Field 9	Field 10
AF	00	1000	P	N	T	T	P	N	1

Field 8	ball seats	
	P	Polypropylene
	S	AISI 316
	A	Aluminium
Field 9	O-Rings	
	D	EPDM
	V	FPM
	T	PTFE
	N	NBR
Field 10	connections	
	1	BSP Threated

HYDRAULIC CHARACTERISTICS

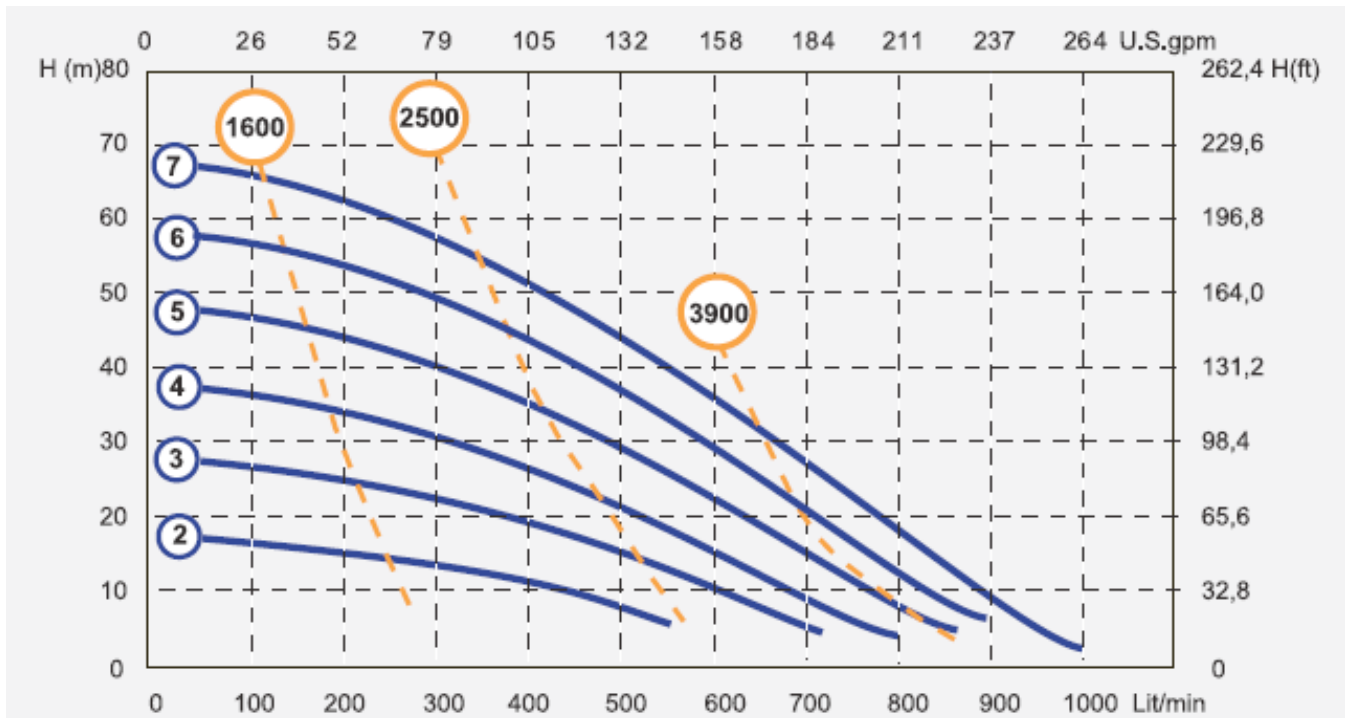

* The curves and performance values refer to pumps with submerged suction and a free delivery outlet with water at 20°C, and vary according to the construction material.

OPERATING PRINCIPLE

The pneumatic distribution system sends compressed air behind one of the two diaphragms (A), which pushes the fluid towards the delivery circuit. Simultaneously, the opposing diaphragm (B) is located, creating a vacuum in the chamber B, in the suction phase, moved from the shaft that connect the diaphragm to the other (A). In this way the product is sucked from the intake manifold, thanks to de-pressure created in the fluid chamber. When the diaphragm (A), under pressure, reaches the limit of the stroke the distributor switches the two inputs, and the cycle starts again. At the same time, the balls open and close, alternating the chamber A and B, in the closed situation for suction and open delivery in the situation.

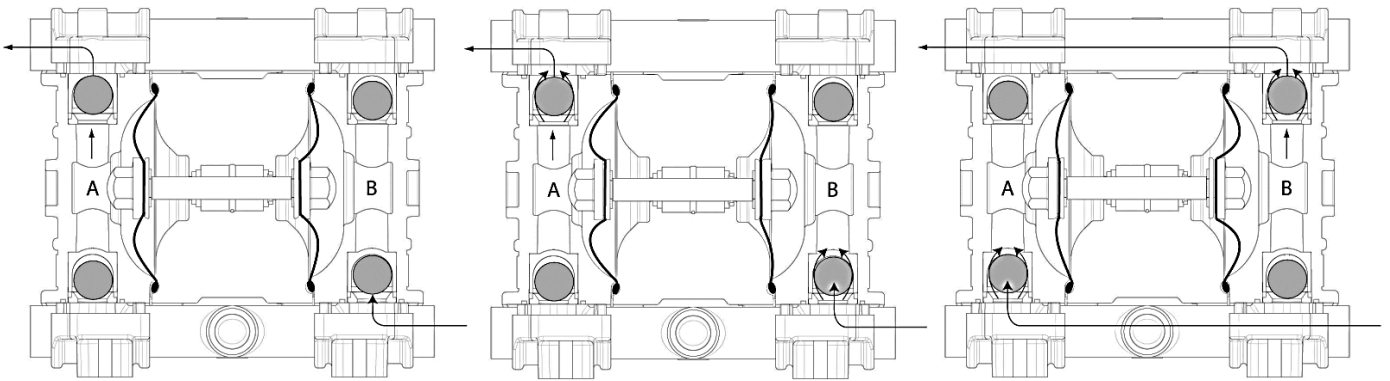

DIMENSIONS

PP

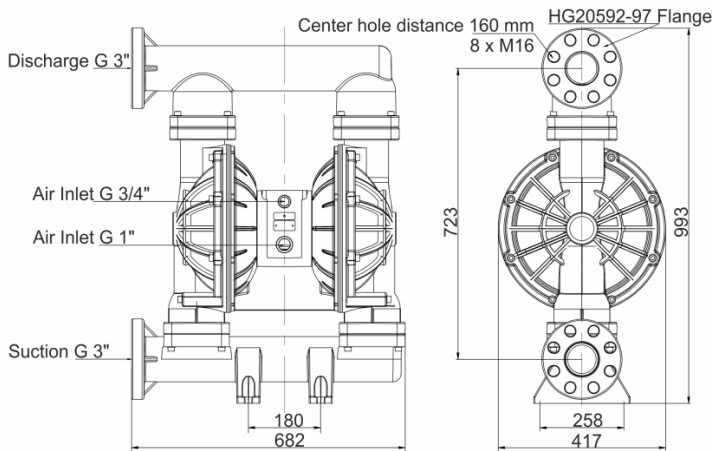

ALUMINIUM - SS316

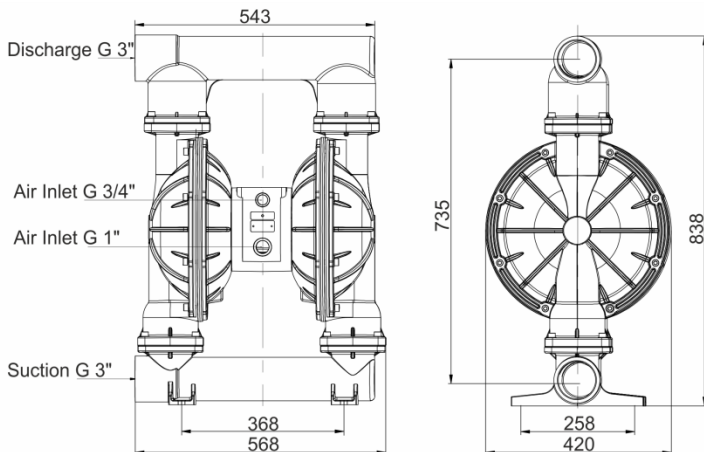

TEMPERATURE

PP	65°C
ALU	95°C
SS	95°C