

Technical characteristics

- Connections: 3/8"
- Max Flow-rates: 18 l/min
- Max delivery head: 70mt
- Max air pressure: 7 Bar
- Air connections: 6mm
- Max suction head: 6mt
- Max d. passing solids : 2,5mm
- Pump casing materials:
 - PP
 - PVDF
 - POMc
 - SS

DUOTEK diaphragm pumps are characterized by exceptional performance, power and strength, making them ideal for pumping liquids with very high apparent viscosity up to 50000 cps (at 20°C), even if containing suspended solids.

The stall-prevention pneumatic system assures a safe pump running and it does not need lubricated air.

Self-priming dry capacity even with considerable suction head, fine tuning of speed without pressure loss and the possibility of dry operation without suffering damage mean that these pumps offer unrivalled versatility. In addition, the huge choice of construction materials allows selection of optimum chemical compatibility with the fluid and/or environment without neglecting the temperature range.

They are specifically designed for demanding applications with high humidity or in potentially explosive atmospheres (ATEX Certification).

MAIN FEATURES

- . construction's materials: PP, PVDF, AISI 316, POMc
- . Self-priming up to 6m
- . Unlimited dry running
- . Anti-stall pneumatic circuit , easy to maintain
- . possibility to adjust: flow-rate, head and speed
- . ATEX certifications for Zone 1 and 2 in all versions

PUMP KEY CODE

Field 1	Field 2	Field 3	Field 4	Field 5	Field 6	Field 7	Field 8	Field 9	Field 10
AF	00	0018	P	N	T	T	P	N	1

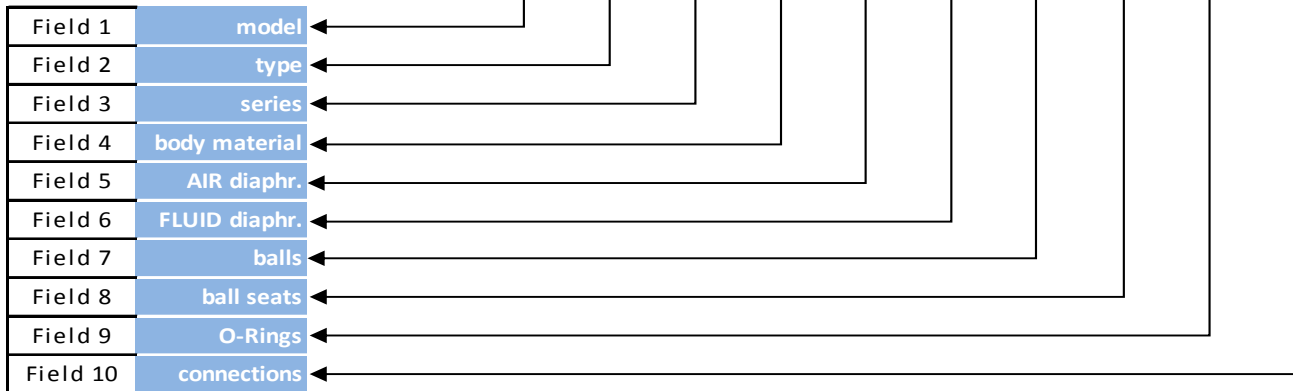

Field 1 **model**
AF Pneumatic Diaphragm Pumps

Field 2 **type**
00 Zone 2 ATEX
X0 Zone 1 ATEX

Field 3	series [l/m]	connection [BSP]	max head [m]	max pressure [bar]	air connection [BSP]	self priming [m]	passing solid [Ø mm]
	0018	3/8" *	70	7	3/8"	6	3,5
* Flanged on request							

Field 4 **body material**

P	Polypropylene	if Field 2 = X0, P = PP+CF
K	PVDF pure	if Field 2 = X0, K = PVDF+CF
S	SS 316	
M	POM	if Field 2 = X0, M = POM+CF

Field 5 **AIR diaphr.**
N NBR

Field 6 **FLUID diaphr.**
T PTFE

Field 7 **balls**

T	PTFE
S	SS 316
D	EPDM
N	NBR

PUMP KEY CODE

Field 1	Field 2	Field 3	Field 4	Field 5	Field 6	Field 7	Field 8	Field 9	Field 10
AF	00	0018	P	N	T	T	P	N	1

Field 8 ball seats

P	Polypropylene
K	PVDF pure
S	AISI 316
A	Aluminium
Z	PE-UHMW

Field 9 O-Rings

D	EPDM
V	FPM
T	PTFE
N	NBR

Field 10 connections

1	BSP Threaded
2	Flanged

HYDRAULIC CHARACTERISTICS

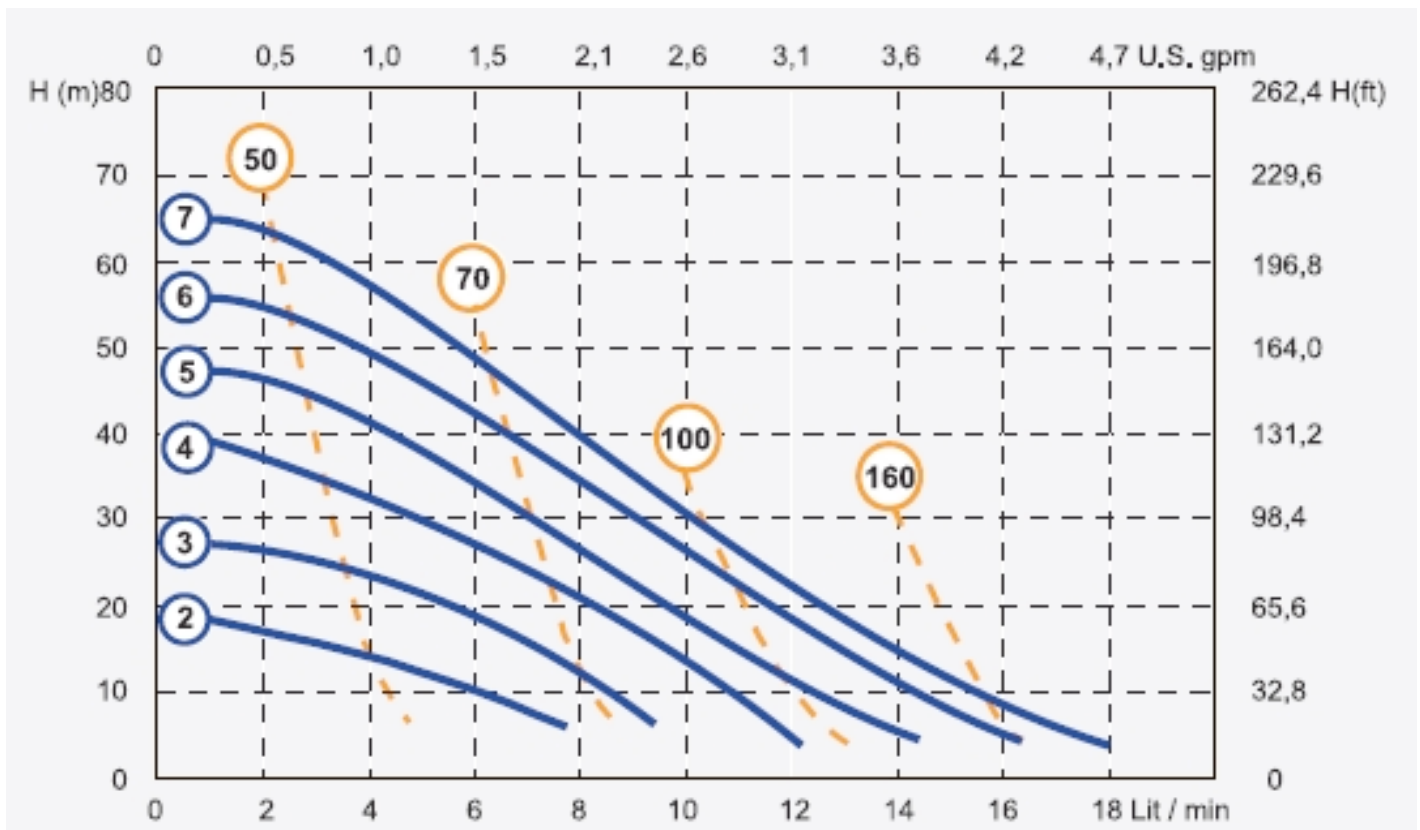

* The curves and performance values refer to pumps with submerged suction and a free delivery outlet with water at 20°C, and vary according to the construction material.

OPERATING PRINCIPLE

The pneumatic distribution system sends compressed air behind one of the two diaphragms (A), which pushes the fluid towards the delivery circuit. Simultaneously, the opposing diaphragm (B) is located, creating a vacuum in the chamber B, in the suction phase, moved from the shaft that connect the diaphragm to the other (A). In this way the product is sucked from the intake manifold, thanks to de-pressure created in the fluid chamber. When the diaphragm (A), under pressure, reaches the limit of the stroke the distributor switches the two inputs, and the cycle starts again. At the same time, the balls open and close, alternating the chamber A and B, in the closed situation for suction and open delivery in the situation.

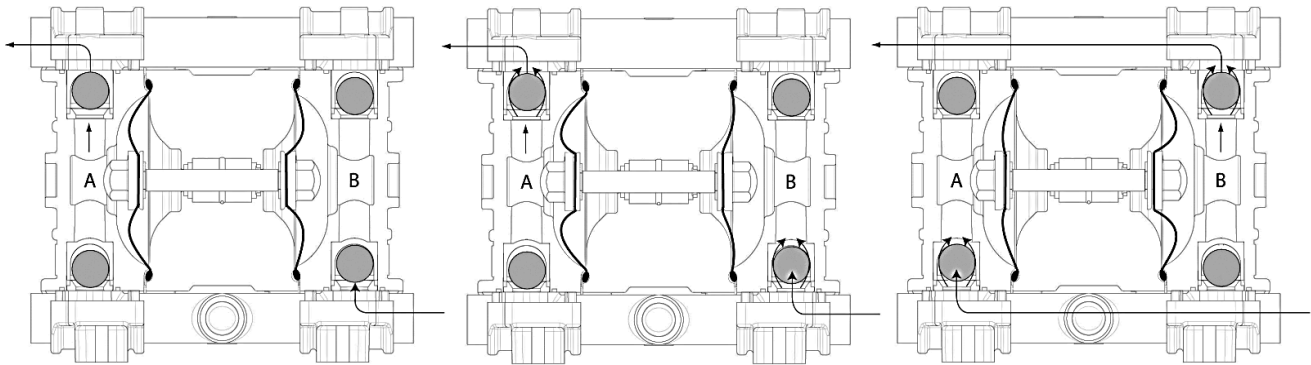

DIMENSIONS (ALL materials)

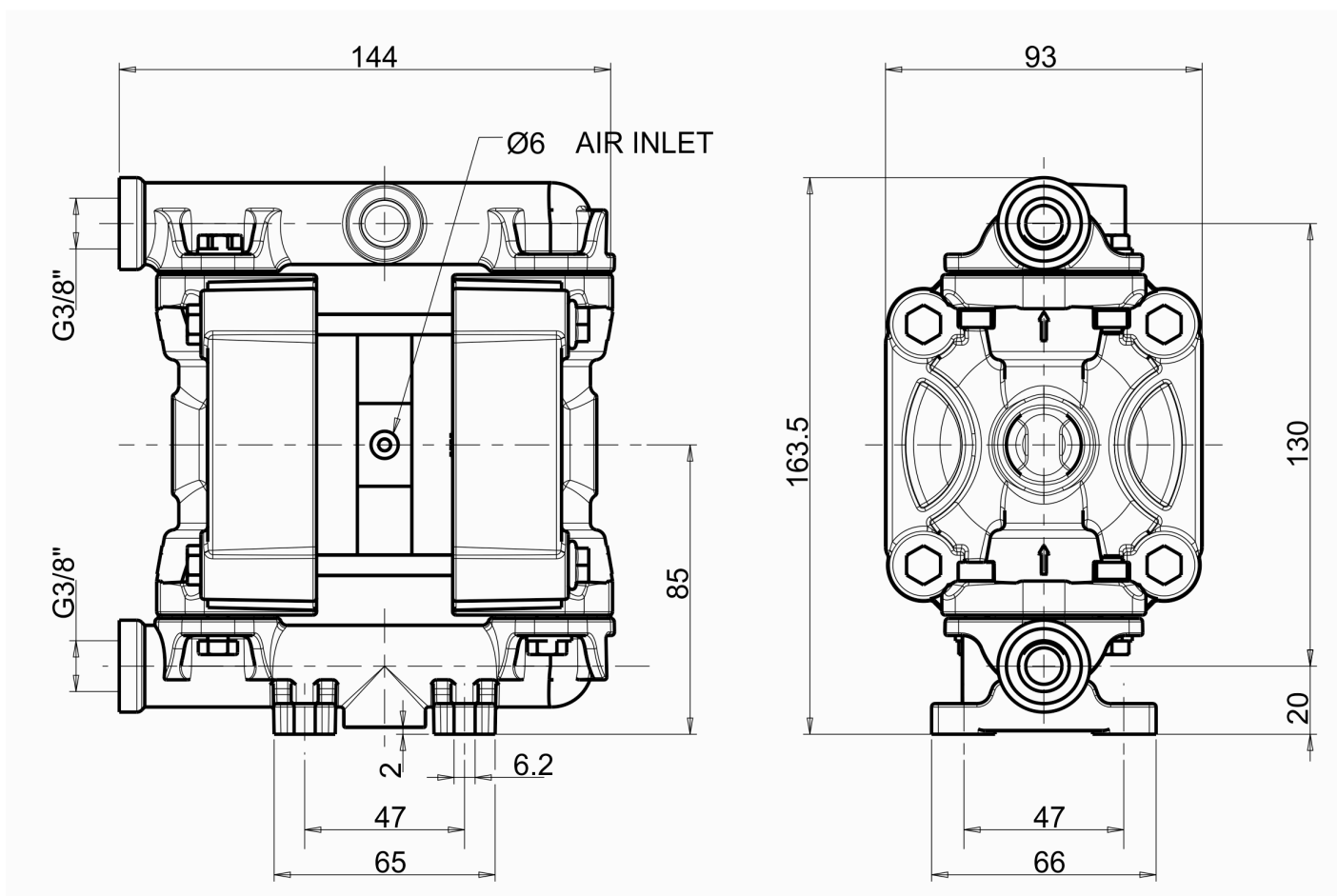

TEMPERATURE

PP	PVDF	POMc	SS
65°C	95°C	95°C	95°C